

LIFT & TURN METALLIC CAP

All Shaw caps feature non rotating seals which last the life of the vehicle.

Key Features

- Compatible with diesel fuel, hydraulic oil, and service fluids
- Lockable design with optional standard padlock
- Rollover safe meets 70/221 EEC. Leak tight during side slope or extreme vehicle operations

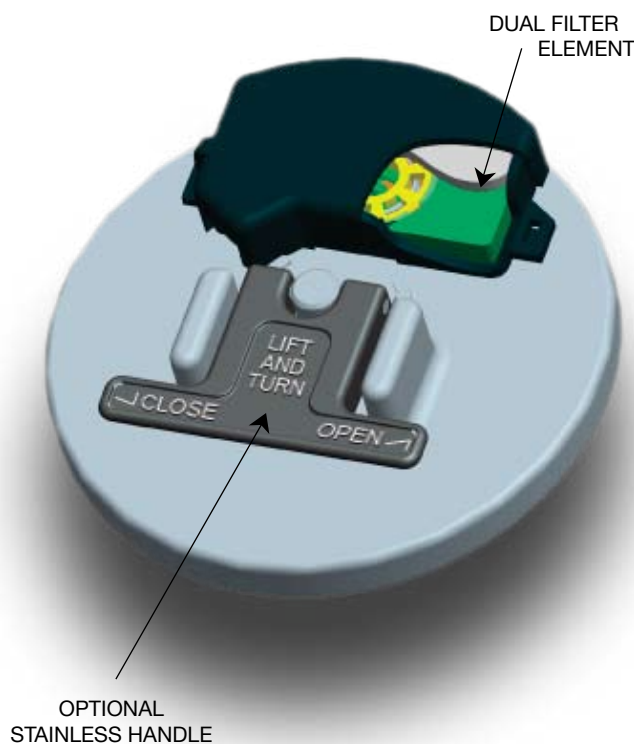

General Specifications

- Manufactured from impact resistant cast aluminum and composite materials
- Does not allow water to enter tank from outside sources such as rain or vehicle wash downs
- Fits standard 4" [100mm] filler openings
- Use with filler nozzles up to 3.25" diameter

Operation

The lift and turn design handle offers simple one hand operation. To remove the cap raise the handle, turn it counterclockwise, and lift the cap off of the adapter.

Available Options

- Custom logos and fluid symbols available
- Custom colors and finishes available
- Venting: Non venting, positive venting, vacuum venting or any combination.
- Special covers and debris guards for severe military applications



The Shaw Military Series Products are custom designed to fit your specific needs. Designed primarily for off-road construction equipment, agricultural equipment, and military applications, Shaw can custom engineer that particular part that you just can't seem to find anywhere else.

FILTRATION AND VENTING SPECIFICATIONS

- Field replaceable filter cartridge
- Low cracking pressures which reduce stresses on fuel tank and fuel pump and enable usage with composite tanks
- Positive venting to relieve pressure within tank caused from thermal expansion, but no leakage on side slope or in rollover situations.



STRAINER OPTIONS AVAILABLE

Perforated Metal, or Screen Mesh in any size or length.

See strainer data sheet for specifications

FILLER NECK & ADAPTERS AVAILABLE

Metallic or Plastic - Weld on, bolt on, thread on, or press-in options.

See adapter data sheet for specifications

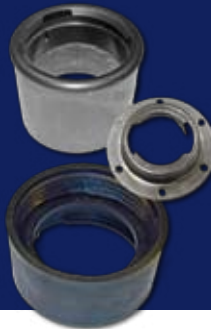

LIFT & TURN METALLIC CAP

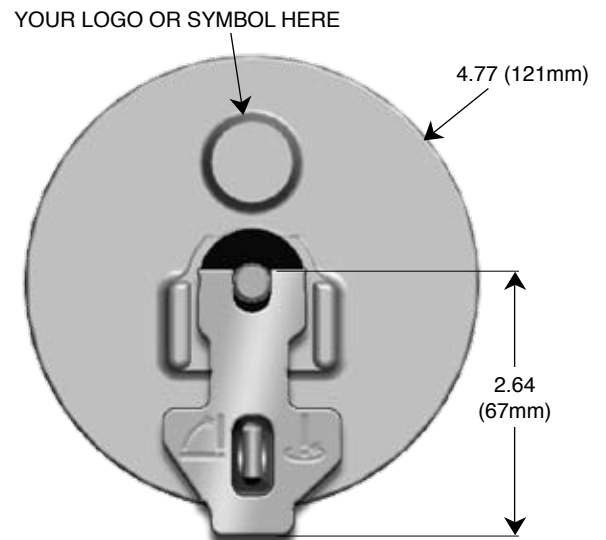

Cap Configuration Matrix	STANDARD	OPTIONS	CUSTOMIZED
CAP COLOR	Unfinished	Black Painted	Any
FILTRATION	120μ	10μ	<10μ
FLUID SYMBOL	Fuel	Hydraulic	Any
VENTING SPECS	Vacuum & Pressure Relief	Non-Venting or Free Breathing	Special Requirements
LOCKING SPECS	Pad Locking Hasp	Non-Locking	Integral Lock
LANYARD	None	Zinc Plated Steel	Stainless Steel
CUSTOMER LOGO	None	Any	Any

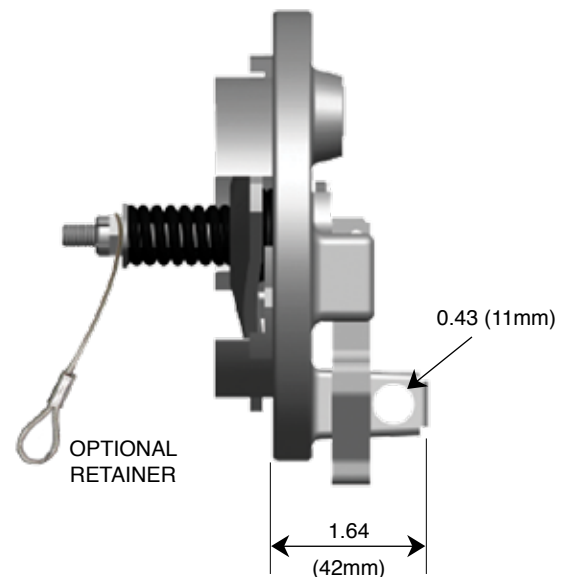

Creating Products for Distinguished Customers