



## QUARTER TURN COMPOSITE CAP

All Shaw caps feature non rotating seals which last the life of the vehicle.

### Key Features

- Compatible with diesel fuel, hydraulic oil, and service fluids
- Lockable design with optional standard padlock
- Rollover safe meets 70/221 EEC. Leak tight during side slope or adverse vehicle operations



LOW VACUUM RELIEF VALVE

DUAL FILTER ELEMENT

NON-ROTATING SEAL

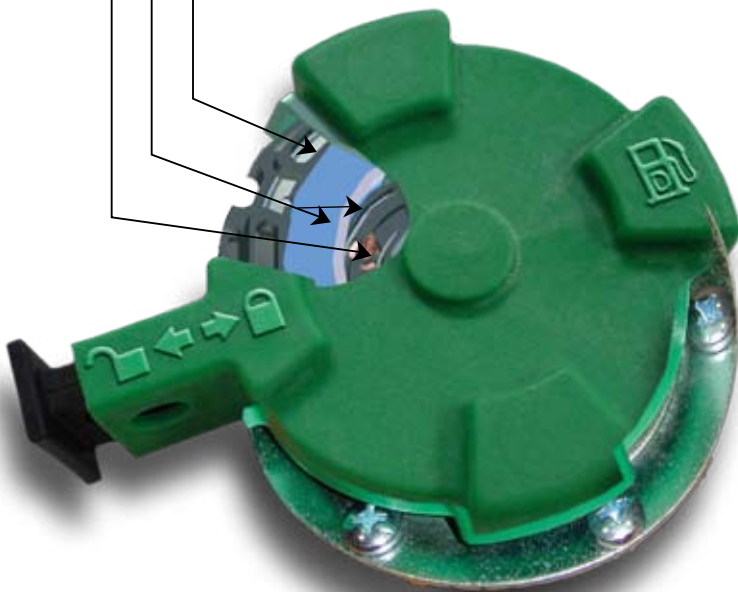

### General Specifications

- Manufactured from impact resistant composites
- Fits standard 58mm OD bayonet style filler necks
- Does not allow water to enter tank from outside sources such as rain or during vehicle wash downs
- Use with filler nozzles up to 1.5" diameter

### Operation

The quarter turn operation allows for opening the cap with one hand. To remove the cap pull out the locking tab, turn the cap counterclockwise 90 degrees, and lift the cap off of the adapter.

### Available Options

- Custom logos, fluid symbols. and colors available
- Non-Vacuum venting, open vented, or two way venting options
- Custom filtration can be incorporated into cap, eliminating the need for a separate filter breather.
- Standard cap design can be modified to meet customer specifications.



The Shaw Commercial Series Products are custom designed to fit your specific needs. Designed primarily for off-road construction equipment, agricultural equipment, and trucking, Shaw can custom engineer that particular part that you just can't seem to find anywhere else.

**FILTRATION AND VENTING SPECIFICATIONS**

- Long life filter element
- 120 and 10 micron nominal filters available
- Low vacuum cracking pressures which reduce stresses on fuel tank and fuel pump
- Positive venting to relieve pressure within tank caused from thermal expansion, but no leakage on side slope or in rollover situations.

**STRAINER OPTIONS AVAILABLE**

Perforated Metal, or Screen Mesh in any size or length. See strainer data sheet for specifications

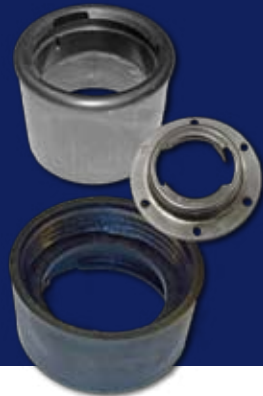

**FILLER NECK & ADAPTERS AVAILABLE**

Metallic or Plastic – Weld on, bolt on, thread on, or press-in options. See adapter data sheet for specifications

**QUARTER TURN COMPOSITE CAP**

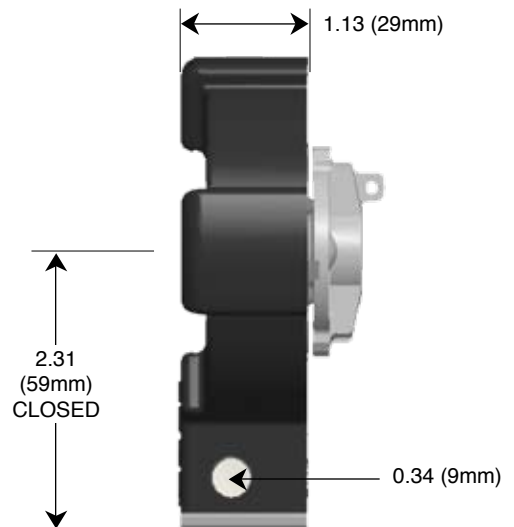
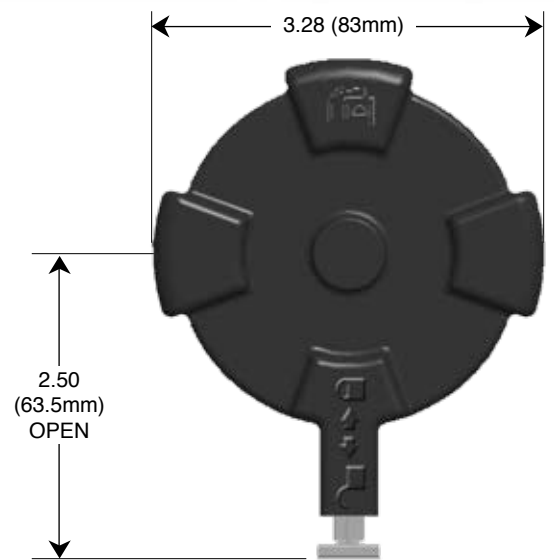

Cap Configuration Matrix	STANDARD CONFIGURATION	BASIC OPTIONS	CUSTOMIZED
CAP COLOR	Black	Green	Any
FILTRATION	120µ	10µ	<10µ
FLUID SYMBOL	Fuel	Hydraulic	Any
VENTING SPECS	Vacuum & Pressure Relief	Non-Venting or Free Breathing	Special Requirements
LOCKING SPECS	Pad Locking Hasp	Supplied with Padlock	Integral Lock with Key
LANYARD	None	Zinc Plated Steel	Stainless Steel
CUSTOMER LOGO	None	Any	Any



Creating Products for Distinguished Customers